

aSi-thin film solar module **SI S22-170.A2**

A special thin film module design causes high energy earnings over a wide range of weather conditions (high module temperatures or at diffuse light). Bypass diodes are deliverable as an option. The maximum system voltage is 1000V. Inverters with grounded inputs are required for the electrical interface.

electric data (@stc)*	unit	
maximum system voltage V		1000
power	W	170
power tolerance	%	+/- 5
V_{oc}	V	192
I_{sc}	A	1.4
V_{mpp}	V	154
I_{mpp}	A	1.1

* standard test conditions if not otherwise specified: 25°C, 1000W / m², AM 1.5

Note: Initial power is 10...20% higher than stabilized power!
All voltages related to the negative power connector of the module.

thermal data	unit	
temperature range	°C	- 40 ... 85
temperature coefficients:		
power	%/K	- 0.20
V_{oc}	%/K	- 0.30
I_{sc}	%/K	+ 0.10

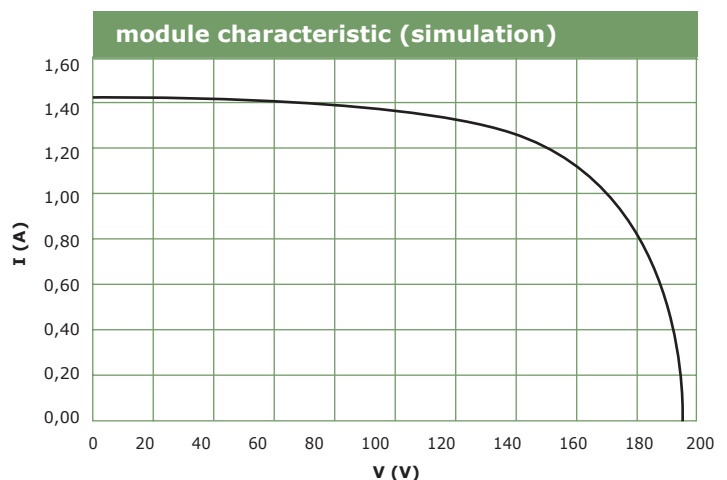

Signet Solar GmbH
Am Fuchsloch 10
04720 Mochau
Germany
phone: +49 3431 6076 100
fax: +49 3431 6076 205

aSi–thin film solar module **SI S22-170.A2**

Signet Solar modules consist of laminated annealed float glass in a frameless design including a junction box in the centre of the back side. The modules are made in Germany (modern full integrated process) and are 100% end of line tested. The module power is guaranteed over life time with 90% (10 years) and 80% (25 years).

Because of the use of nontoxic materials Signet Solar modules are easily recyclable. Module mounting should be carried out with special fixation systems.

mechanical data	unit	
height	mm	1300
width	mm	2200
thickness (laminate)	mm	8
weight	kg	60
static load	N/m ²	2400

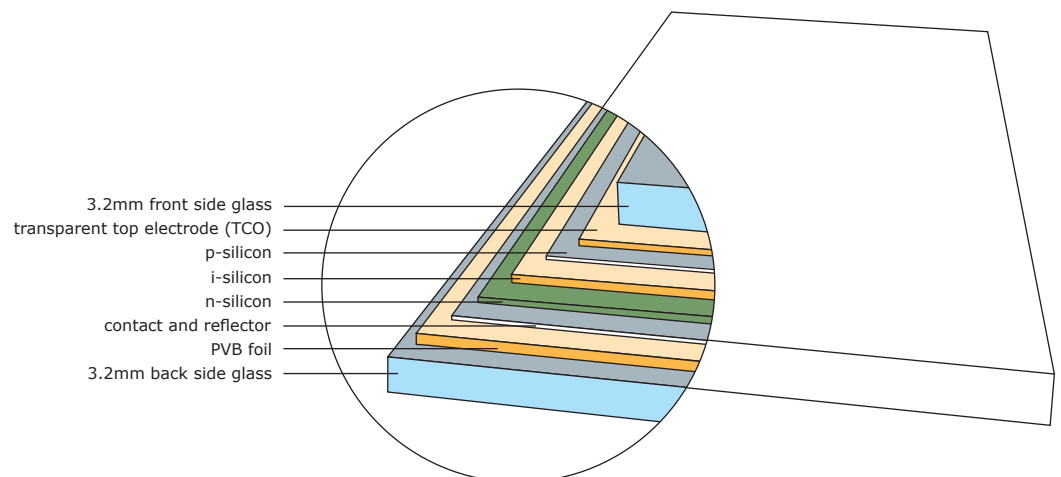
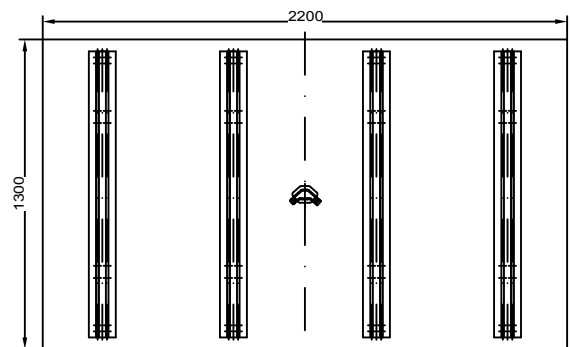

All changes reserved!